

Savwinch Tips

Operating Instructions

1. To drop the anchor, go past your mark and put the boat in reverse and idle back.
2. When you are ready, press down on the rocker switch panel to release the anchor. Observe the operation and ensure there is tension on the rope. Be sure not to overrun the rope on the drum.
3. Once the rope becomes loose/slack, stop the downwards operation. If at this point more rope is required to be released, jog/inch the down on the rocker switch panel until the slack rope becomes tight again.
4. When satisfied with the position and the amount of rope released, switch off the engine.
5. To retrieve the anchor, start your engine and idle forward whilst pushing up on the rocker switch panel.
6. Observe the operation and be ready to stop as the anchor reaches the top bow roller. At this point jog/inch into lock position on the bow roller.
7. We recommend that you carry a spare rope and anchor for safety reasons.

Warranty

The warranty agreement you enter into when you make a Savwinch winch purchase is subject to the following conditions and limitations:

1. The warranty period comes into effect as of the date of invoice generation/written agreement is made.
2. Savwinch manufactured products are warranted to be free from defects in materials and workmanship.
3. If your Savwinch product is suspected of being defective in materials or workmanship you must cease using it and contact Savwinch to report the fault within 7 days of noticing the defect.
4. The warranty will include either repair or replacement of the faulty part/s, material or workmanship.
5. The purchaser is responsible for any charges associated with removal, returning the faulty goods to Savwinch for warranty claim and reinstallation.
6. Any damage sustained to any vessel, property, equipment or persons due to the installation or use of a Savwinch product, as far as is permitted by consumer law, is excluded from this warranty.

This warranty shall be limited or null and void if any of the following occur:

1. The improper installation of a product, including not adhering to the installation guidelines contained within this manual
2. The improper and irregular maintenance, repair or service of your Savwinch product
3. The improper use or incorrect application of your Savwinch product, including excessive force
4. Water Corrosion neglect by EG High pressure spraying, submerging motor or not spraying lubricant as instructed
5. Improper modification/s made to the product

Warranty terms as follows:

SSS Winches (Motor, Gearbox, Drum): 7 Years

SS Winches (Motor, Gearbox, Drum): 5 Years

CS Winches (Motor, Gearbox, Drum): 3 Years

Switching Gear & EFF Electronic Fast Fall Units: 2 Years

All other accessories: 1 Year

*Warranty does not cover damaged goods, ex/cut rope kits, Bowsprits bent by force, etc



Installation and User Manual For Savwinch Winches and Electronic Fast Fall



Thank you for your recent Savwinch purchase. Savwinch prides itself on producing industry leading innovative products, and having excellent customer service. We endeavour to meet and exceed our customers' needs in relation to the use of their Savwinch products and any service or warranty issues should they arise. Our wish is that you get many years of effective and enjoyable use of your Savwinch and that your experience with Savwinch is a positive one. Welcome to the Savwinch family!

Standard Savwinch Installation

Recommended wire for Savwinch models, to begin from motor wires to the battery.

880 Series -> 6 B&S (13.5mm²)
 1000 & 1500 Series -> 4 B&S (20mm²)
 2000, 3000, & 4000 Series -> 3B&S (25mm²)

Installation Tips

- Both exposed wires from Savwinch Motor must be connected via Joiners/solder and then heat shrink, to eliminate any corrosion or water entering wires when attaching power cables to other attachments.
- The drum must be in line and centered to the Guide Roller or Hawse Pipe in order to ensure an even spread of the rope and chain to the drum.
- Gearbox output flange to drum bracket can rotate in 12 different mounting positions for your motor and gearbox components. This will allow you to position motor/gearbox at the most convenient configuration required.
- Ensure the Circuit Breaker is wired between the Isolator/Battery and the Solenoid.
- Regularly spray Switchgear, Terminals, Motor/Gearbox with Lanolin.
- Regularly check all fittings and Winch for any loose parts.
- Ensure the Circuit Breaker is wired as close to the battery as possible.

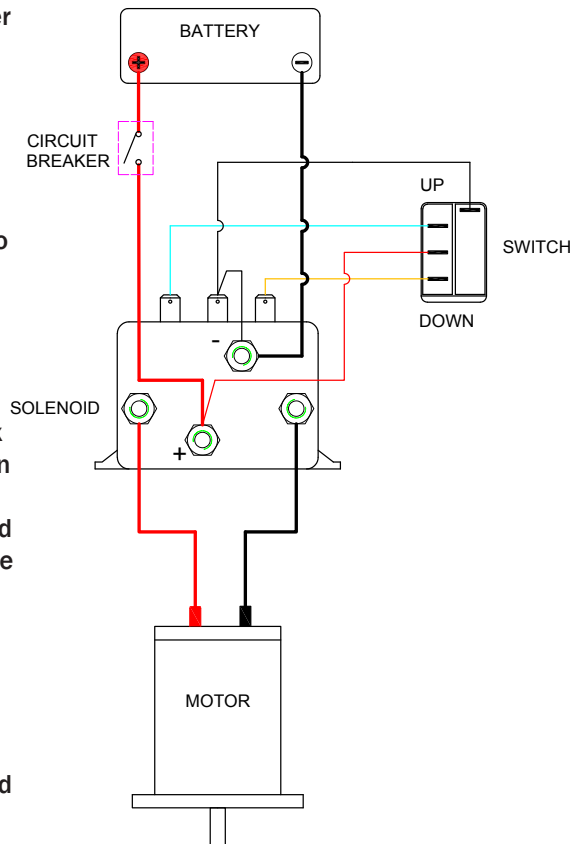
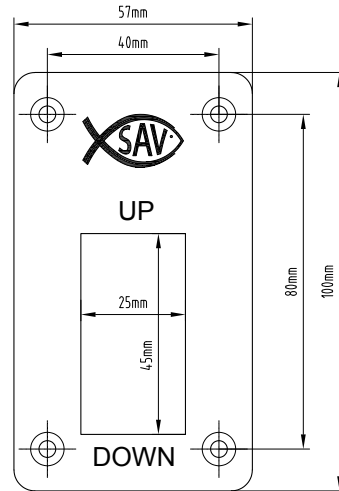

Savwinch EFF Installation

The SAV-EFF-2S is a direct two speed unit. It releases the anchor as soon as the down rocker switch has been pressed. There will be no delay as long as you hold the switch, the anchor will drop at fast fall speed to the bottom. Rope tangles can occasionally occur on barrel. Always ensure correct operation and observe the chain and rope are falling fast and retrieving at normal speed.

Installation Tips

- Must join at least 1m of cable (See left page for correct cable size) between motor and EFF.
- No Direct connection from the motor wires to EFF.
- Do not cross wires on the battery side, this will cause the EFF to malfunction and void warranty.
- EFF must go down fast. If not, swap the motor wires around. Using it the wrong way will void warranty.
- Ensure the Circuit Breaker is wired between the Isolator/Battery and the EFF.
- Regularly spray Switchgear, Terminals, Motor/Gearbox with Lanolin.
- Regularly check all fittings and Winch for any loose parts.
- Ensure the Circuit Breaker is wired as close to the battery as possible.

