

Owners Installation & Operation Manual

Please read this user manual carefully before using the product



Model: PRO VN600 with nylon base

PRO VA600(C), VA1000(C) with aluminum base

PRO VS600(C), VS1000(C) with stainless steel base

PRO CV600,CV1000 with stainless steel base



04/2012

South Pacific Industrial Pty Ltd. Australia

TEL: +61 (0)2 9659 2889 FAX: +61 (0)2 9634 5368

e-mail: info@southpacific.com.au

www.southpacific.com.au

CONTENTS

- I FEATURES**
- II PACKAGE CONTENTS**
- III SPECIFICATIONS**
- IV INSTALLATION**
- V OPERATION**
- VI MAINTENANCE**
- VII WARRANTY**
- VIII IMPORTANT INFORMATION**
- IX PARTS LIST**

I FEATURES

- Self tailing rope/chain combination stainless steel gypsy
- Efficient spur gears provide tremendous lifting capacity
- Heavy duty DC motor with long life and high output torque
- High efficient permanent magnet motor with low current draw
- Build-in torque limiter for extra protection
- One-Piece design with no separate parts, easy to install
- Strong structure and long performance life
- Emergency retrieval handle bar included

II PACKAGE CONTENTS

●	WINDLASS	× 1
●	CONTROL DEVICE	× 1
●	HANDLE BAR	× 1
●	USER MANUAL	× 1
●	MOUNTING TEMPLATE	× 1
●	ACCESORIES : Thread rod M8 × 100mm	× 3
	Nut M8	× 3
	Washer M8	× 3
	Split Washer M8	× 3

III SPECIFICATIONS

	VN600 / VA600, VS600	VA1000/VS1000
Suit Boats Size	18ft~28ft / 18ft~32ft	28ft ~ 42ft
Handle Anchor Size	27lb / 30lb	42lb
Comparable Model	700W Model	1000W Model
Input Voltage	DC 12V	DC 12V or 24V
Max. Working Load	300kg(660lb)	450kg(1000lb)
Typical Working Load	45kg(100lb)	72kg(160lb)
Retrieval Speed	20m(67ft)/min.	18m(60ft)/min.
Pay-out Speed	22m(75ft)/min.	20m(67ft)/min.
Continuous Working Time	Max. 15 minute	Max. 15 minute
Typical Current Draw	18A(12V)	25A(12V) or 13A(24V)
Motor Type	Permanent magnet	Permanent magnet
Motor Wattage I/O	800W/300W	1100W/450W
Motor Efficiency	75%	82%

Gear Type / Efficiency	Spur Gear/92%~97%	Spur Gear/92%~97%
Chain Size	6, 7, 8mm, 1/4", 5/16"	
Rope Size	12, 14mm, 1/2", 9/16"	
Dimension	195x130x275mm. 7.7"x5.1"x10.8"	
Weight: without Capstan	5.0kg / 6.5kg / 8.5kg 11lb / 14.3lb / 19lb	7kg(15.4lb) / 9.0kg(20lb)
with Capstan	Non / 7.5kg / 9.5kg Non / 16.5lb / 20.9lb	8kg(17,6lb) / 10kg(22lb)

South Pacific Industrial Pty Ltd reserves the right to alter or change specifications without notice.

It is very important to choose the correct type of rope and chain, to ensure proper running of the windlasses.

Rope- Must use three strand, medium-lay. We recommend Filament Polyester, Premium Nylon or Silver rope(Australia). **Do not use soft rope.** Soft rope (either polyester or nylon) will slip and cause a rope jam in the gypsy. It will also lock the gypsy and cause circuit breaker to pop-up often.

Chain- Must ensure that the inside length "p1" is suitable for the gypsy. Otherwise, the chain will get stuck(too small) or slip(too big) in the gypsy and eventually damage the release arm. Please refer to the chart below.

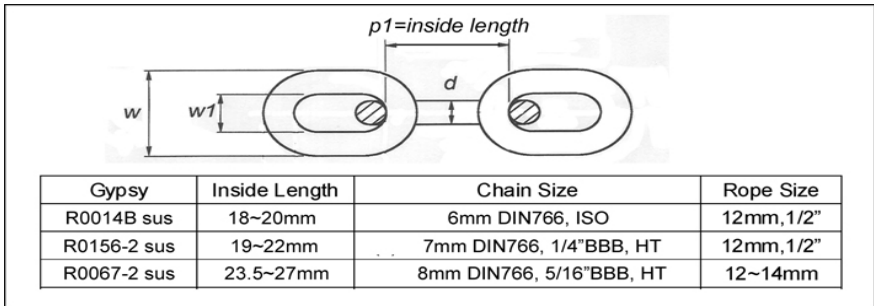

Note: The rope size indicated is its actual diameter measured

IV INSTALLATION

1. TOOLS REQUIRED

a. Electric drill



b. Adjustable spanner



c. Jig saw



d. File



e. Philips head screwdriver



f. Silicon glue

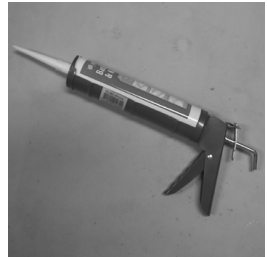

2. PLANE

- a. First of all, a suitable Bow Roller must be installed to support the anchor, chain and rope.
- b. A bollard or snubbing device should be installed between the bow roller and windlass to tie the rope on while being anchored or securing the anchor in the fully raised position.

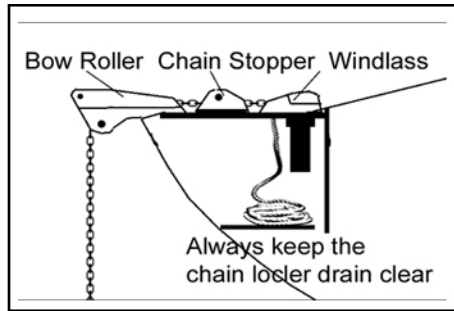
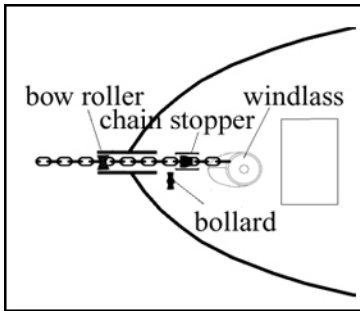

- c. If you are using only chain, a chain stopper should be installed between the bow roller and the windlass to take the drag force away from the windlass while being anchored.
- d. Ensure there is a drain in the chain locker and always keep it clear to prevent the water level rising and make sure the chain locker is deep enough to store the rope and chain. If the anchor well is not deep enough the rope and chain will build very quickly and block the entrance.

3. CONSTRUCTION

- a. Place the windlass on the deck and find a suitable position for it, with reference to the vessel's bow roller, rope and chain locker below.
- b. Place the mounting template on the deck in the desired position for the windlass and hold it in place using adhesive tape
- c. Use a 10mm(3/8") diameter drill to make three holes for the mounting thread rods

- d. With a jig saw, cut the hole for the gear box and rope and chain to pass through. Use a file to smooth any rough edges. To avoid water absorption by the deck, apply paint to the cut hole edges
- e. Secure thread rod to the base of the windlass, then apply a silicon sealant to the base of the windlass and around the thread rod. Secure the windlass firmly to the deck from below using the nuts and washers supplied
- f. Mount control device at a suitable position either in the cabin or close to the operating area.
- g. Connect the windlass, control unit and power source using electric cable indicated below. Keep the power supply cable as short as possible. Too thin and/or too much length of electric cable will reduce the performance of the windlass or cause the circuit breaker to work incorrectly.

Model	Heavy Cable Size	Switches cable size	Circuit Breaker
710, 800, V600 series (12V)	AWG 8 or 8mm ²	AWG 18~20	CB-001-30 (30A)
900, V1000 series (12V)	AWG 6 or 13mm ²	AWG 18~20	CB-001-50 (50A)
900, V1000 series (24V)	AWG 8 or 8mm ²	AWG 18~20	CB-001-30 (30A)
V1500 series (12V)	AWG 4 or 21mm ²	AWG 18~20	CB-003-90 (90A)
V1500 series (24V)	AWG 6 or 13mm ²	AWG 18~20	CB-003-50 (50A)

- h. There is one control system that is included in the package, please refer to the connection diagram below.

◆ Direct control system:

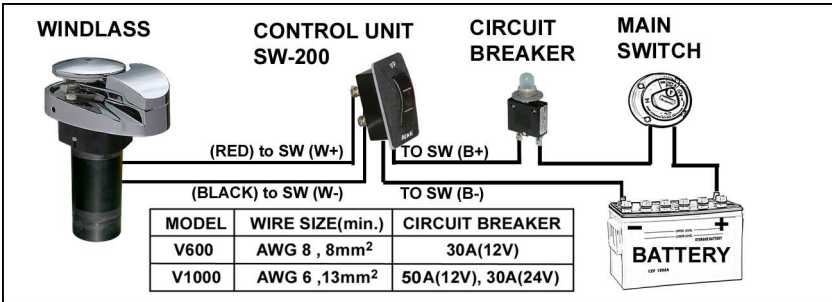

Note: For safety reason, do not connect the power source direct to the battery. Please connect the power cable to the main power switch on your boat.

SW-200 with dynamic brake, can not be parallel.

◆ Indirect control system:

Using foot switches or hand held switch for multiple control, a solenoid K-200 is necessary.

If you have an existing control unit (SW-030 or SW-200), you **must remove it** before installing this indirect control system. Also, **do not** attach control unit (SW-030 or SW-200) to K-200 as an up/down switch (SW-025).

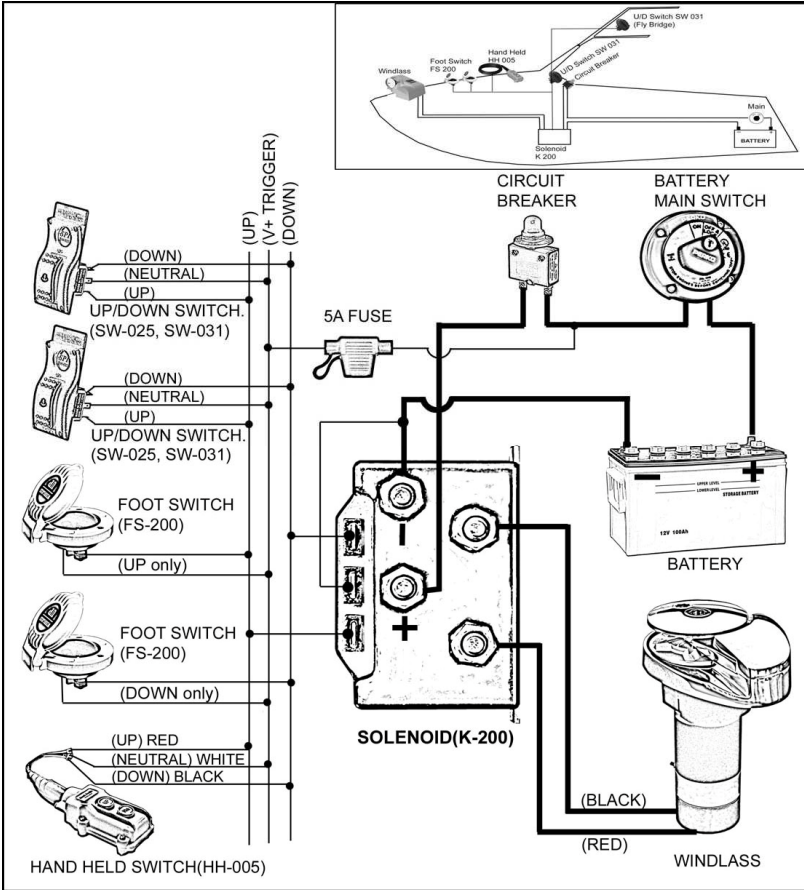

NOTE: The direct control system and indirect control system can not exist concurrently.

If the winding direction is not as desired, please change over the wires from the windlass to the solenoid K-200.

4. TO INSTALL ANCHOR ROPE AND CHAIN

To splice the rope to the chain, please follow the steps below.

Do not use a hook or shackle.

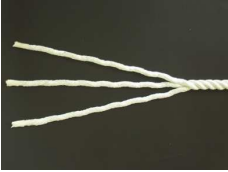

STEP 1:

Unravel the end of the rope for about 20cm and secure the end of the strands with tape.



STEP 2:

Pass three strands through the last link of the anchor chain. Untwist the rope to raise a strand just below the tie on the standing part of the rope and insert one strand under it, then pull the strand through. Twist the strand to keep it tightly wound as you pull it through.



STEP 3:

Take the next strand on the left. Tuck it under the next strand to the right of the one under which the first strand was tucked. Pull it through as before.



STEP 4:

Now turn the whole eye over. Take the last strand and make the tuck as before under the only strand on the standing part of the rope not used yet. Stop and ensure that each working strand has gone over a strand and under a strand, and that the whole lot is pulled tight and twisted in its natural sense. No two strands

should come from under the same strand.



STEP 5:

For the remained rounds of tucks, take each end over one strand and under the next one to the right, in the same order as before.



STEP 6:

To finish, pull the ends tight. Cut the excess off with a hot knife. A good way to do this is by heating a butter knife with a butane torch, or a gas stove if handy. This cuts and seals the individual strands resulting in an excellent frayless finish.



STEP 7:

After you've spliced the rope to the chain, tie both ends of the splice rope to prevent the rope from loosening.

V OPERATING

1. During operating, if the circuit breaker bounces it means the motor is overloaded. After about 10 seconds press the button to reset.
- 2 Pay out the rope and chain approximate 2~3 times the water's depth for a firm casting while being anchored.

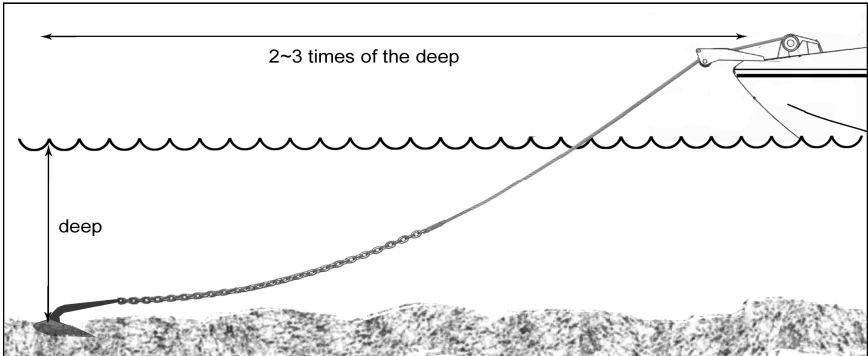

3. Keep limbs, fingers, clothing and hair clear of the windlass and anchor to avoid possible personal injury during operation.
4. ***Tie the anchor rope firmly to the bollard when the anchor is cast and the boat is moored.*** Do not allow the windlass to take the force of a boat's drag. If using all chain, a chain stopper is necessary between the bow roller and windlass to take the force of the boat's drag.
5. When retracting the anchor, untie the rope from the bollard. Then move the boat to the position just above the anchor by boat 's engine power(not windlass power)

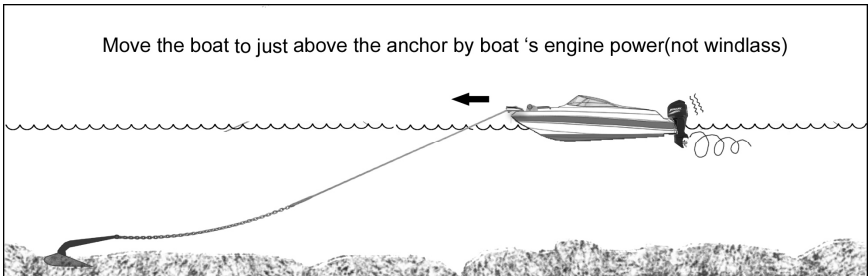

and switch on the windlass to lift it back. When the anchor is close to the bow roller, ***slow down the roll in by pausing the switch.***

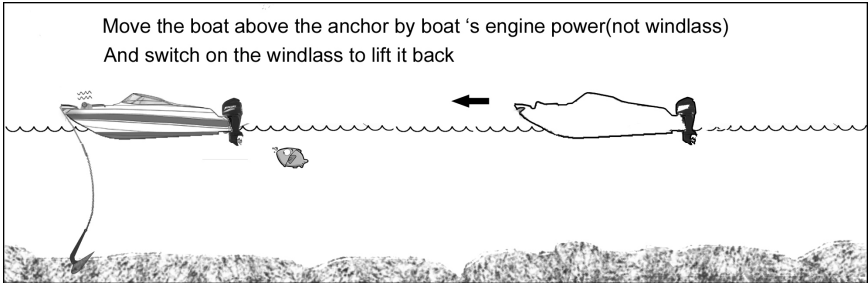

NOTE: The windlass is designed to lift the anchor, rather than to drag the boat or for mooring.

6. If the anchor is stuck on the seabed or reef, detach it by the boat's engine power before operating the windlass or else it may cause damage or overstrain the windlass.
7. **After use, secure the anchor firmly in place** in the boat by extra device(such as hook, shackle...) to avoid damage caused by anchor falling during transport.



8. The anchor windlass is not designed for continuous operation. Do not use for more than **15 minutes** at a time under loading. Allow an interval of 20~30minutes after each operation.
9. For windlasses with capstan model only:
You may operate gypsy and capstan separately by loosening the

nut on the top of the capstan approx. one turn and the windlass drive shaft will drive only the capstan.

10. Emergency manual retrieval:

If there is a power failure or unit failure, you can remove the gypsy cover and the torque limiter and attach the handle bar to the gypsy for manual operation.

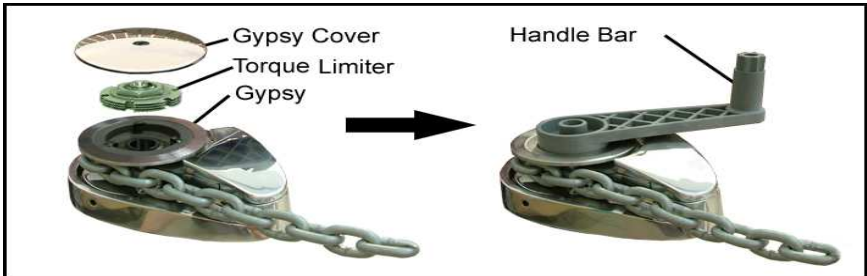

11. The chain tunnel cover can be opened by lifting it up and turning it sideways..

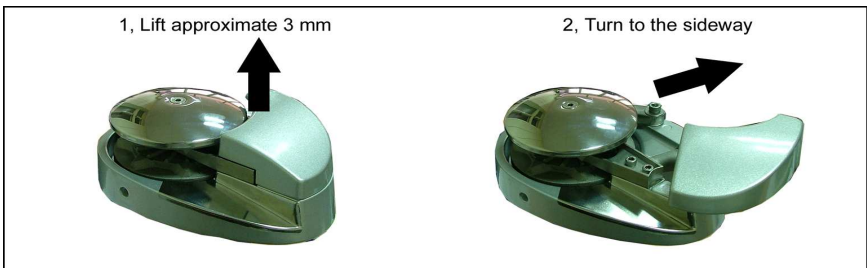

★OPERATING SAFETY IS THE FIRST PRIORITY★

VI MAINTENANCE

1. The V Series windlasses come with a sealed grease lubricated gear box. There is no need for extra lubrication.
2. In order to allow the windlass to perform at optimum capacity and extend its life, use fresh water to wash off salt water after each use.
3. *Always keep the chain locker drain clear to prevent water damage on the motor.*

VII WARRANTY

1. The warranty is deemed as effective only under conditions of normal operation, maintenance and without modification of the product.

2. CLAIMS

If the product needs servicing, please send it back (or bring it to us) with the proof of purchase and we will investigate the product free of charge before repairing. However, the cost of postage or removal from the boat will be borne by the owner.

3. LIMITATIONS AND EXCLUSIONS

The warranty will be deemed effectively only if used on a non-commercial basis and will be invalid under the following conditions:

- a. Operation exceeds the designed specifications
- b. Use for purposes other than indicated
- c. Disassembly or modification of the product
- d. Installation of other parts on the product

-
- e. Third party products even if associated or used together with this product.

VIII IMPORTANT INFORMATION

1. In every circumstance, the operator must make safety as the first priority. An inexperienced person or a child should not operate this product. The manufacturer takes no responsibility for any damage, property loss or injury caused from improper operation.
2. If a product is accepted for refunding, the manufacturer is not responsible for any renovation of the boat.

IX PARTS LIST:

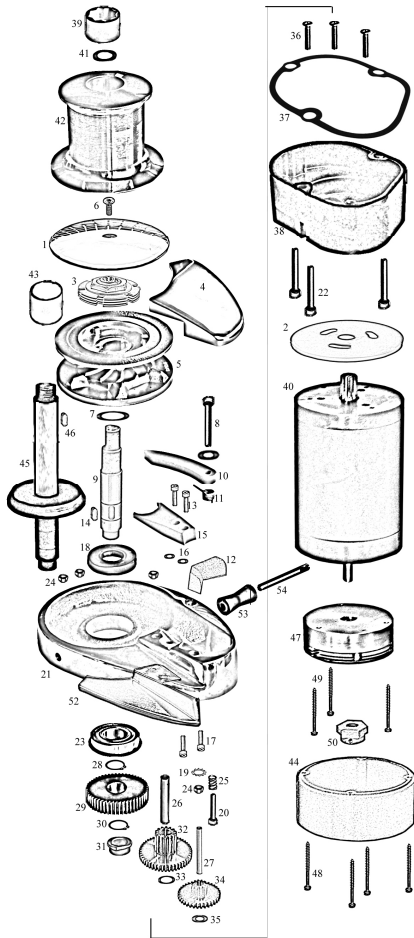

PRO VN600, VA600(C), VA1000(C), VS600(C), VS1000(C)

	Parts No.	Item: PRO V series
1.	R0346	Gypsy Cover
2.	R0163	V700 motor gasket
3.	A0002(14)(24)	Torque Limiter(6)(1)
4.	R0170(N)(A)(S)-2	Chain Tunnel Cover
5.	Gypsy refer to the chart below	
6.	R0024-15	Screw M6x15 sus
7.	R0121	Sus Washer M18x1.5
8.	R0197-40	Sus M6x40
9.	R0347	Pro V Drive Shaft
10.	R0169S	Tension Arm sus
11.	R0184	Tension Arm Spring
12.	R0268	Bush sus(A)
13.	R0023-(15)	M5x15 Screw sus
14.	R0095-I	6x15 key
15.	R0168S	Release Arm sus
16.	R0222	M5 Bronze Washer
17.	R0023-(12)	M5x12 sus(A)
18.	R0072	Oil Seal
19.	R0194	Washer
20.	R0197(40)	Screw M6x40 sus
21.	R0166(N)(A)(S)	Base
22.	SR0197-(35)(45)	
23.	R0075	Ball Bearing
24.	R0216	M6 Nut
25.	R0200	Spring
26.	R0172	No.3 Shaft
27.	R0173	No. 2 Shaft
28.	R0069J	19mm S Clip
29.	R0176	No. 4 Gear
30.	R0069-I	19mm S Clip
31.	R0003	Bush
32.	R0177	No. 3 Gear
33.	R0223	10.5x0.3 mm Washer
34.	R0179	No. 2 Gear
35.	R0224	6.5x0.3 mm Washer
36.	R0212	M5x25
37.	R0175	V600 Gasket
38.	R0165	Gear Box
39.	R0206-S	Capstan Nutt(C)
40.	R0211,R0186-2	Motor V700 or V1000
41.	R0221	M16 bronze washert(C)
42.	R0187	Capstan 64mm(C)
43.	R0339	VC shaft socket(C)
44.	R0407	V700 Brake Cover
45.	R0171(C)	Main Drive Shaft(C)
46.	R0095-s	6x15 key sus(C)
47.	A0010-V	Electric Brake
48.	R0232-40	3x40 screw sus
49.	R0153-23	3x23 screw
50.	R0404	Drive hub
51.		
52.	R0217	Chain way panel (A)
53.	R0218	Roller(N)
54.	R0219	Roller shift(N)
55.	Note: (N): VN series only	
56.	(A): VA series only	
57.	(S): VS series only	
58.	(C): with capstan model	
59.		
60.		

Gypsy	Suit Chain	Suit Rope
R0014-B	6mm	12mm, 1/2"
R0156-2	7mm, 1/4"	12mm, 1/2"
R0067-2	8mm,5/16"	12-14mm

Thank you for choosing South Pacific products

Purchase Date:	Model:
Supplier Name:	
Address:	
Phone:	Fax: